

KUKA | Xpert

Identification number: AR7161

| | |
|------|--|
| 货号 | 0000-153-427 |
| 材料状态 | 10 - 批准预生产 |
| 制造商 | KUKA Roboter |
| 产品图片 |  |

Spare parts

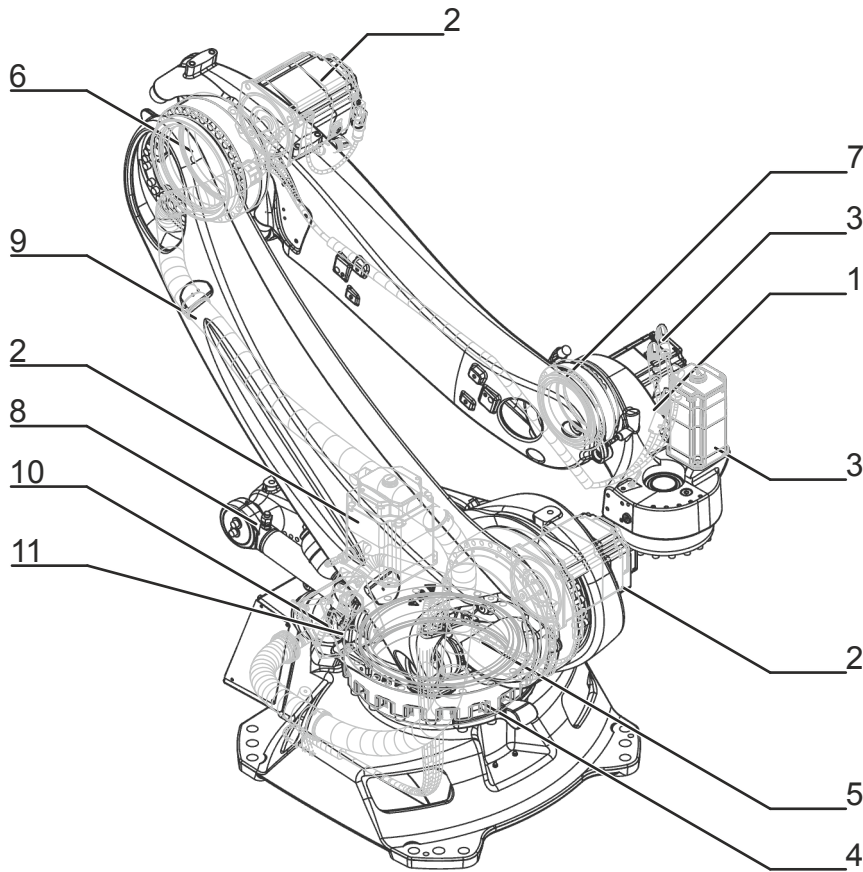

Spare parts graphic KR 120 R3200 PA arctic , schematic representation

| Pos. | Article number | Designation | Component | Work instruction |
|------|----------------|---|----------------------------------|---|
| 1 | 0000-245-225 | SPP wrist Quantec PA arctic | Wrist | |
| 2 | 0000-192-295 | SPP AC servomotor I2/1FK7101 | Motor A1 Motor A2 Motor A3 | Exchanging motor A1 Exchanging motor A2 Exchanging motor A3 |
| 3 | 0000-192-297 | SPP AC servomotor D01/1FK7063 | Motor A5 Motor A6 | Exchanging motor A5 Exchanging motor A6 |
| 4 | 0000-245-236 | SPP Gearbox RV-400CS i=219,03 arc,no oil | Gear A1 | |
| 5 | 0000-245-235 | SPP Gearbox RV-550N I=235,37 arc, no oil | Gear A2 | |
| 6 | 0000-245-234 | SPP Gearbox RV-320ES I=241 arctic,no oil | Gear A3 | |

| Pos. | Article number | Designation | Component | Work instruction |
|------|----------------|---|----------------------------|------------------|
| 7 | 0000-245-233 | SPP Gearbox RV-160N i=125,21 arc, no oil | Gear A5 | |
| 8 | 0000-245-232 | SPP counterbalancer heavy arctic | Counterbalancing system | |
| 9 | 0000-237-970 | KRC4 roboter cable set Quantec PA arctic | Cable set | |
| 10 | 0000-236-268 | Resolver Digital Converter RDC Cool | RDC | |
| 11 | 0000-236-267 | Electronic Data Storage EDS Cool | EDS | |

Export to Excel 

Maintenance information

Gear oil



The quantity of oil drained depends on the draining time and the oil temperature. The refilling quantity is the quantity of oil that was drained from the gear unit at the correct operating temperature and with the correct draining time. This oil quantity must be determined. Only this quantity of oil may be used when refilling.

If less than 70 % of the specified oil quantity flows out, flush the gear unit with the determined quantity of drained oil once, then pour in the amount of oil that was drained. If less than 50% of the specified oil quantity flows out (e.g. inclined installation), the flushing operation must be repeated twice. During the flushing procedure, move the axis at jog velocity throughout the entire axis range.

The oil quantities specified in the table correspond to the oil quantities in the gear unit at first filling.

| Gear oil new filling quantity | |
|-------------------------------|--------|
| A1 | 6.50 l |
| A2 | 2.40 l |
| A3 | 1.90 l |
| A4 | - |
| A5 | 0.80 l |
| A6 | 1.20 l |
| Gear oil refilling quantity | |
| A1 | 5.20 l |
| A2 | 2.00 l |
| A3 | 1.80 l |
| A4 | - |
| A5 | 0.70 l |
| A6 | 1.10 l |

Counterbalancing system

| | |
|------------------------|---------|
| Gas pressure p0 | 156 bar |
| Oil pressure p1 | 176 bar |

技术数据

基本数据

| | KR 120 R3200 PA arctic |
|-----------------------|---------------------------------------|
| 轴数 | 5 |
| 可控制的轴数 | 4 |
| 工作空间体积 | 77.9 m ³ |
| 位姿重复精度 (ISO 9283) | ± 0.06 mm |
| 重量 | 约 1075 kg |
| 额定负荷 | 120 kg |
| 最大负载能力 | - |
| 最大运动范围 | 3195 mm |
| 防护等级 (IEC 60529) | IP65 |
| 机器人腕部防护等级 (IEC 60529) | IP65 |
| 噪声等级 | < 75 dB (A) |
| 安装位置 | 地面 |
| 占地面积 | 830 mm x 830 mm |
| 运动系统安装面布孔图 | S934 |
| 允许倾角 | ≤ 5 ° |
| 标准色 | 底座： 黑色 (RAL 9005); 活动部件： 库卡橙色 2567 |
| 控制系统 | KR C4 |
| 变压器名称 | KR C4: KR120R3200PA C4 FLR |

环境条件

| | |
|-----------------------|--------------------------------|
| 湿度等级 (EN 60204) | - |
| 环境条件分类 (EN 60721-3-3) | 3K3 |
| 环境温度 | |
| 运行时 | -30 °C 至 10 °C (243 K 至 283 K) |
| 仓储和运输时 | -40 °C 至 60 °C (233 K 至 333 K) |

轴数据

| | |
|----------|---------------|
| 运动范围 | |
| A1 | ±185 ° |
| A2 | -140 ° / -5 ° |
| A3 | 0 ° / 155 ° |
| A4 | - |
| A5 | - |
| A6 | ±350 ° |
| 额定负载时的速度 | |
| A1 | 124 °/s |
| A2 | 115 °/s |
| A3 | 112 °/s |
| A4 | - |
| A5 | 217 °/s |
| A6 | 242 °/s |

工作区域

Dimensions: mm

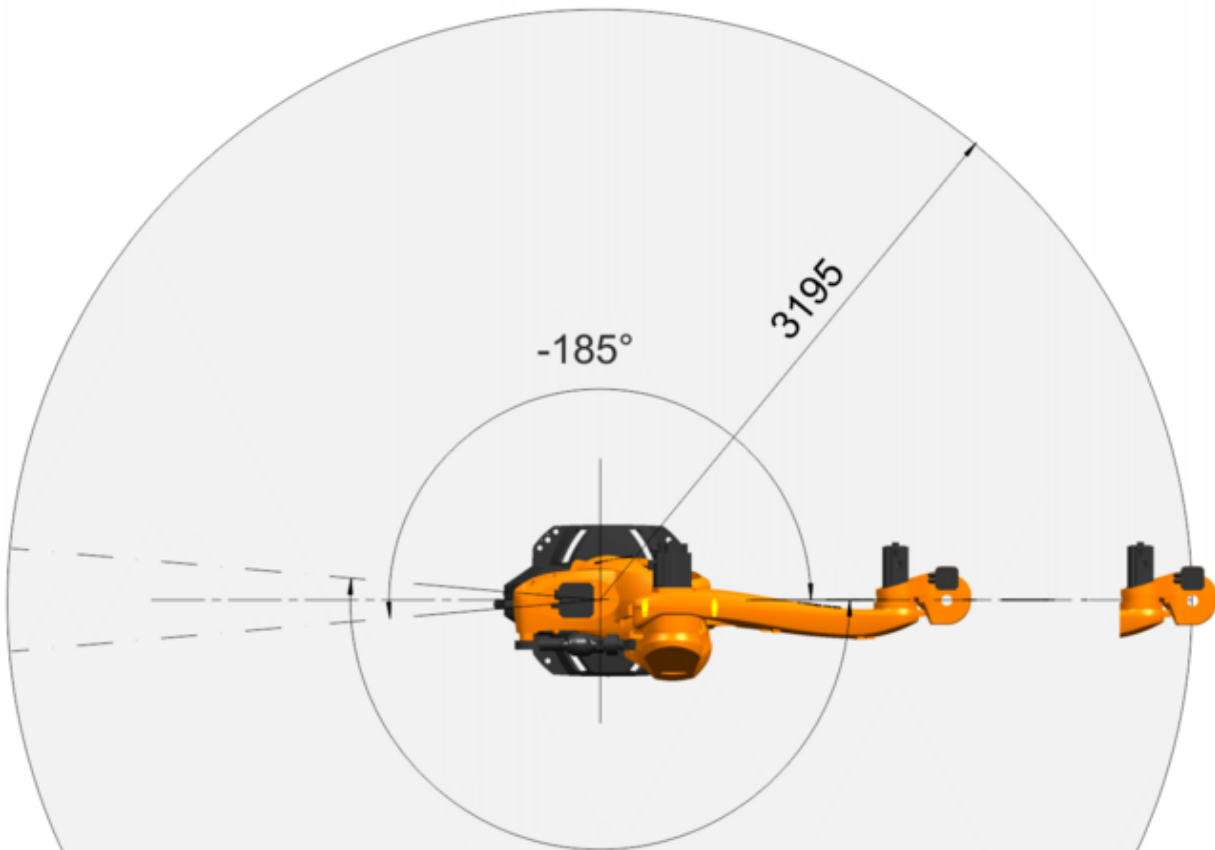
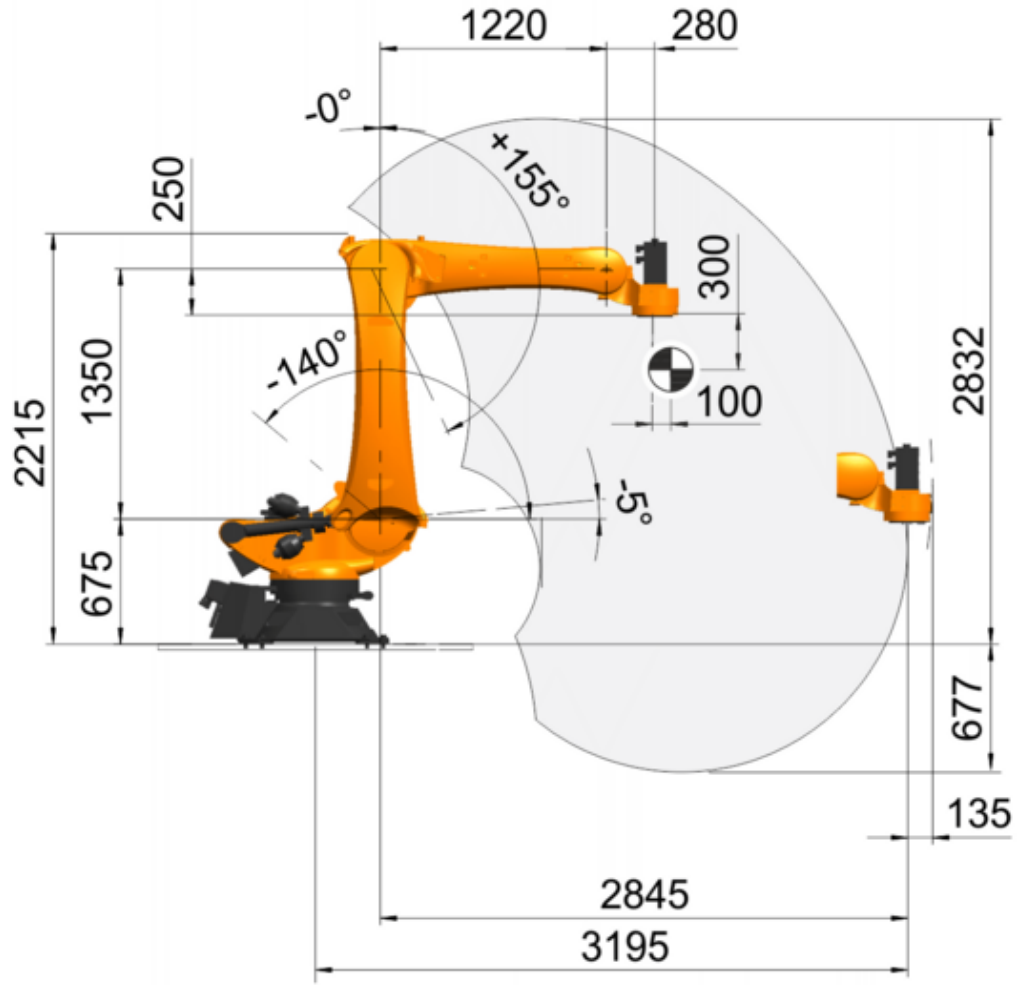



KR 120 R3200 PA 工作区域

负载能力

| | |
|----------------------------------|---------------------|
| 额定负荷 | 120 kg |
| 最大负载能力 | - |
| 法兰 I_x 额定质量转动惯量 | 60 kgm ² |
| 法兰 I_y 额定质量转动惯量 | 60 kgm ² |
| 法兰 I_z 额定质量转动惯量 | 60 kgm ² |
| 底座的额定附加负载 | - |
| 底座的最大附加负载 | - |
| 转盘的额定附加负载 | 0 kg |
| 旋转机构的最大附加负载 | 300 kg |
| 大臂的额定附加负载 | 0 kg |
| 大臂的最大附加负载 | 130 kg |
| 小臂的额定附加负载 | 50 kg |
| 小臂的最大附加负载 | 150 kg |
| 负载重心额定距离 | |
| L_{xy} | 100 mm |
| L_z | 300 mm |

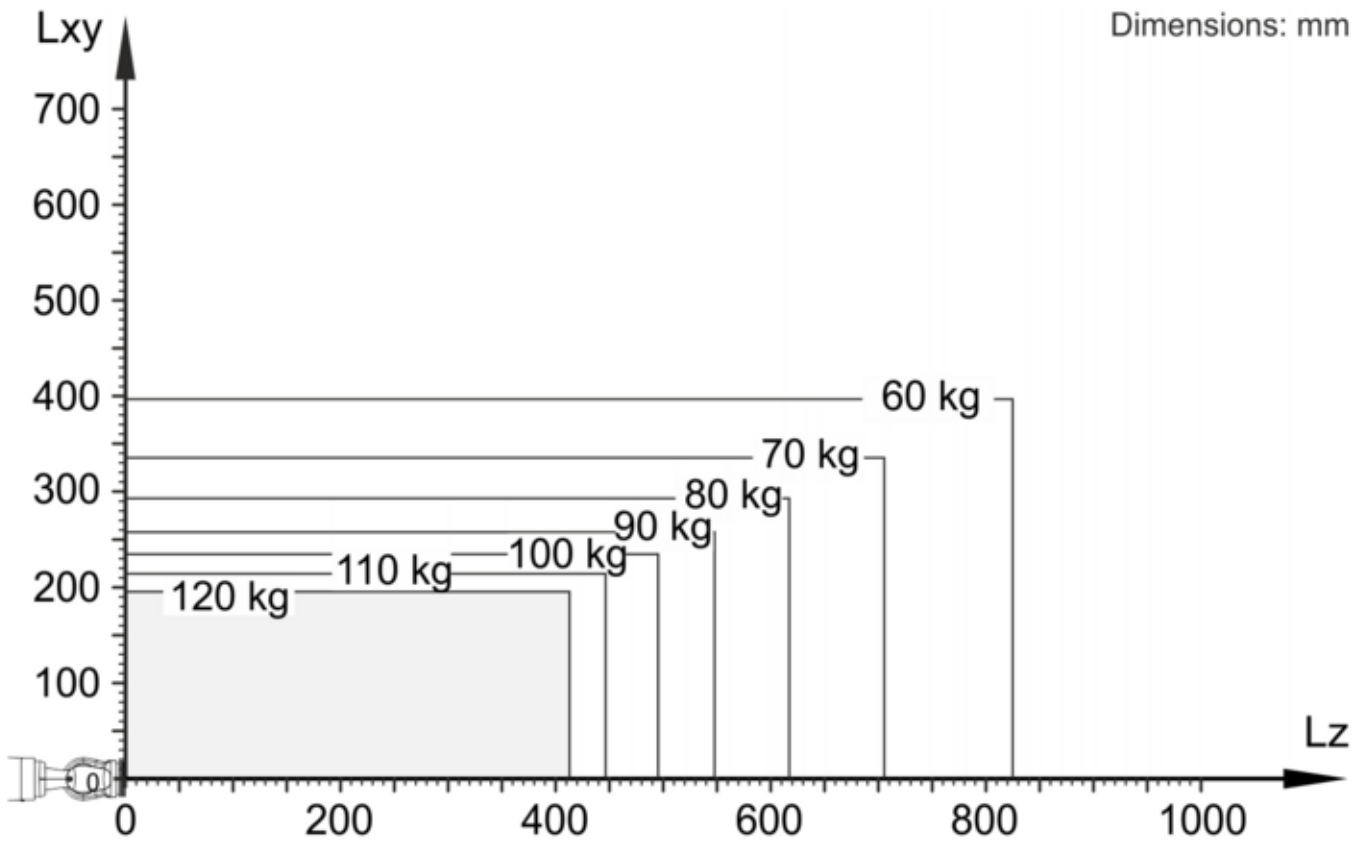

KR QUANTEC PA 负载能力图表，负载能力 120 kg

连接法兰

| | |
|---------|--------|
| 机器人腕部类型 | 120 kg |
| 连接法兰 | 见图纸 |

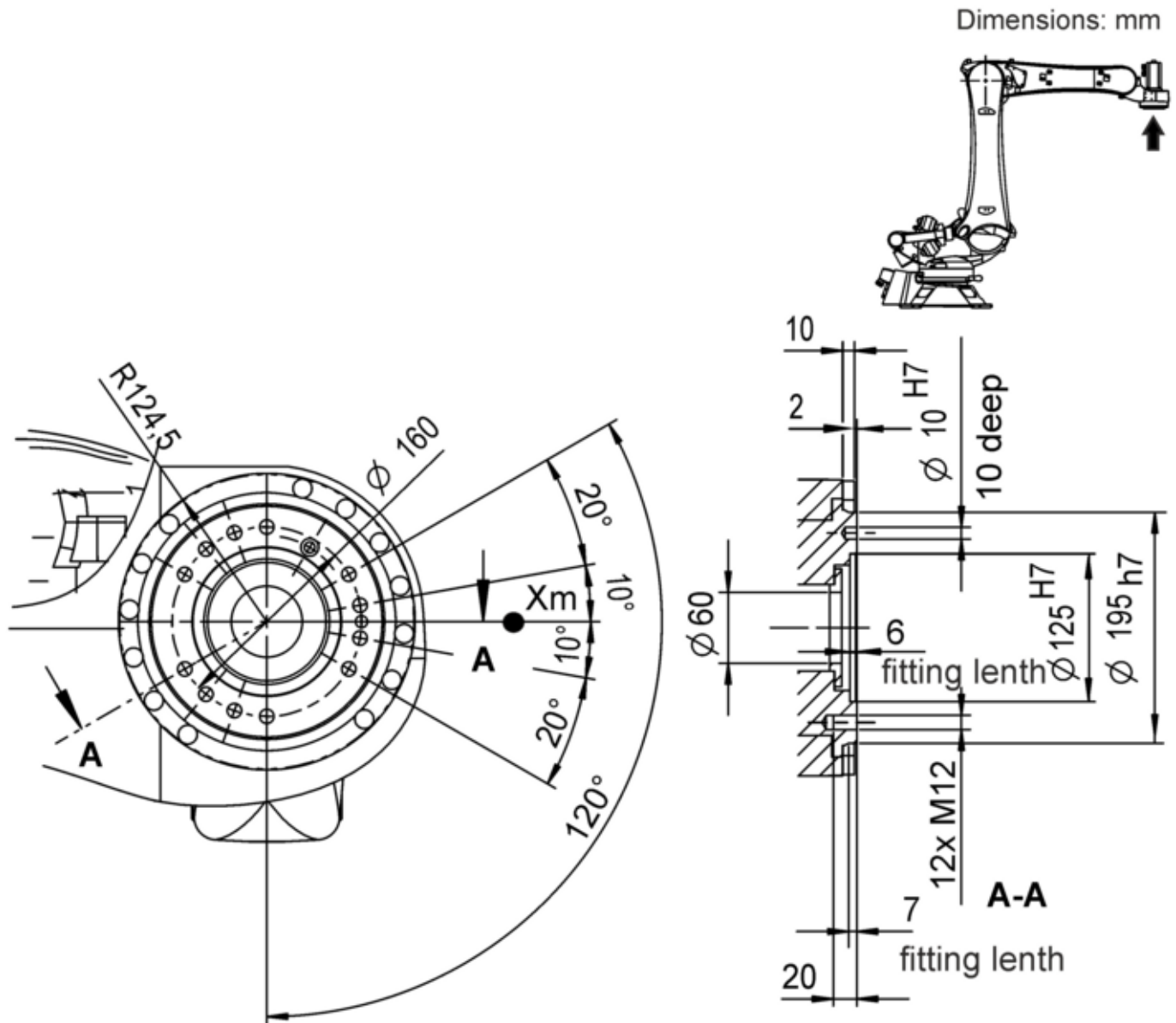

连接法兰，适配器

地基负载

| | |
|--------------------|----------|
| 纵向动力 F(v) | |
| F(v 正常) | 19100 N |
| F(vmax) | 24000 N |
| 横向动力 F(h) | |
| F(h 正常) | 9200 N |
| F(hmax) | 16000 N |
| 倾覆力矩 M(k) | |
| M(k 正常) | 24000 Nm |
| M(kmax) | 49000 Nm |
| 轴 2 转矩 M(r) | |
| M(r 正常) | 10200 Nm |
| M(rmax) | 35000 Nm |

垂直力 $F(v)$ 、水平力 $F(h)$ 、倾斜力矩 $M(k)$ 、轴 1 的转矩 $M(r)$

Flange loads

Flange loads

Due to the motion of the payload (e.g. tool) mounted on the robot, forces and torques act on the mounting flange. These forces and torques depend on the motion profile as well as the mass, load center of gravity and mass moment of inertia of the payload.

The specified values refer to nominal payloads at the nominal distance and do not include safety factors. It is imperative for the load data to be entered in the robot controller. The robot controller takes the payload into consideration during path planning. A reduced payload does not necessarily result in lower forces and torques.

The values are guide values determined by means of trial and simulation and refer to the most heavily loaded machine in the robot family. The actual forces and torques may differ due to internal and external influences on the mounting flange or a different point of application. It is therefore advisable to determine the exact forces and torques where necessary on site under the real conditions of the actual robot application.

The operating values may occur permanently in the normal motion profile. It is advisable to rate the tool for its fatigue strength.

The EMERGENCY STOP values may arise in the event of an Emergency Stop situation of the robot. As these should only occur very rarely during the service life of the robot, a static strength verification is usually sufficient.

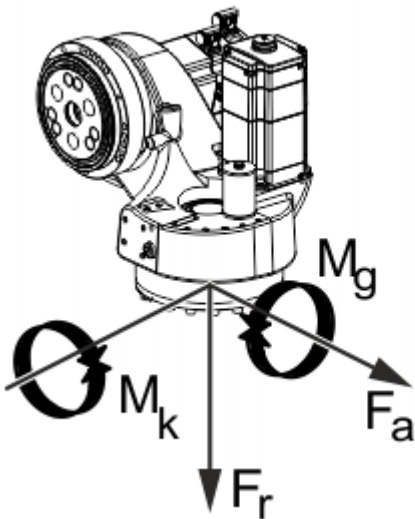

Flange loads

| Flange loads during operation | |
|-------------------------------|--------|
| F(a) | 4100 N |
| F(r) | 4100 N |

| | |
|---|---------|
| M(k) | 1500 Nm |
| M(g) | 1660 Nm |
| Flange loads in the case of EMERGENCY STOP | |
| F(a) | 5400 N |
| F(r) | 6100 N |
| M(k) | 3550 Nm |
| M(g) | 4350 Nm |

Axial force $F(a)$, radial force $F(r)$, tilting torque $M(k)$, torque about mounting flange $M(g)$

Dangerous goods information

The following parts of the product must be considered dangerous goods with regard to their transportation in public spaces:

| Pos. | Article number | Designation | Gas pressure p0 | Nitrogen mass |
|------|----------------|--|-----------------|---------------|
| 1 | 0000-236-011 | Counter Balance System heavy filled arc. | 156 bar | 0.359 kg |

Export to Excel 

For sea or air freight, the following UN number shall apply:

UN 3164 Articles, pressurized, hydraulic (with non-flammable, non-toxic gases)

| | |
|-----------------------------|--|
| UN number | UN 3164 |
| Proper shipping name | Articles, pressurized, hydraulic (with non-flammable, non-toxic gases) |
| Class | 2.2 |
| Explanation of class | Non-flammable, non-toxic gases |
| Example | Filled hydropneumatic CBSs |
| Hazard | <ul style="list-style-type: none"> • Bursting of the pressure vessels (100 - 160 bar) • Splintering not possible • Freezing due to sudden escape of gas |
| Measures | <ul style="list-style-type: none"> • Do not loiter in low-lying areas • If possible, drain oil and depressurize CBS |

关税信息

| | |
|------|--------------|
| 统计货号 | 84795000 |
| 原产地 | DE |
| 制造商 | KUKA ROBOTER |
| 重量 | 1075 kg |

- > **KR 120 R3200 PA arctic** 带有如下的工具 (22)
- > **KR 120 R3200 PA arctic** 有以下选项 (38)
- > **KR 120 R3200 PA arctic** 带有如下的标准组件 (3)
- > **KR 120 R3200 PA arctic** 包含以下危险品 (1)
- > **KR 120 R3200 PA arctic** 需要 (13)
- > **KR 120 R3200 PA arctic** 带有如下的备件 (11)