

KUKA | Xpert

Identification number: AR34708

| | |
|------|--|
| 货号 | 0000-325-892 |
| 材料状态 | 10 - 批准预生产 |
| 制造商 | KUKA Roboter |
| 产品图片 |  |

Spare parts

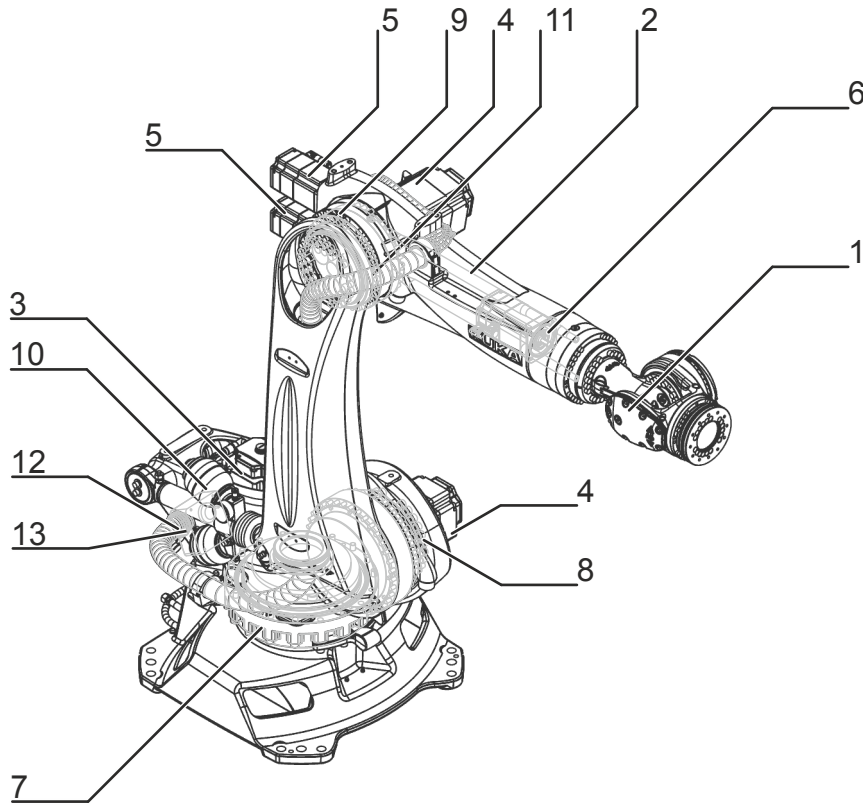

Spare parts graphic KR 250 R2700-2 , schematic representation

| Pos. | Article number | Designation | Component | Work instruction |
|------|----------------|-----------------------------|----------------------|--|
| 1 | 0000-336-010 | SPP IW 300 | In-line wrist | 更换机器人腕部 |
| 2 | 0000-334-487 | SPP shaft Quantec-2 770 COS | Connecting shaft | 更换连接轴 |
| 3 | 0000-334-485 | SPP motor 5.5kW L0 ME | Motor A1 | Exchanging motor A1 更换轴 A2 的电机 更换轴 A3 的电机 Traglast hochrüsten |
| 4 | 0000-334-484 | SPP motor 5.8kW L0 ME | Motor A2 Motor A3 | 更换轴 A2 的电机 更换轴 A3 的电机 Traglast hochrüsten |
| 5 | 0000-334-482 | SPP motor 2.5kW L0 ME | Motor A4 Motor A5 | 更换轴 A4 的电机 更换轴 A5 的电机 Traglast hochrüsten |
| 6 | 0000-334-483 | SPP motor 2.5kW L1 ME | Motor A6 | 更换轴 A6 的电机 |

| Pos. | Article number | Designation | Component | Work instruction |
|------|----------------|-------------------------------------|-------------------------|-------------------------------------|
| 7 | 0000-334-488 | SPP gear unit RV-400CS i=256 (wo) | Gear A1 | |
| | 0000-334-491 | SPP input shaft RV-400CS | | Exchanging gear unit input shaft A1 |
| | 0000-334-492 | SPP input seal RV-400CS | | Exchanging input seal A1 |
| 8 | 0000-334-489 | SPP gear unit RV-550N i=269 (wo) | Gear A2 | |
| | 0000-334-493 | SPP input shaft RV-550N | | Exchanging gear unit input shaft A2 |
| | 0000-334-494 | SPP input seal RV-550N | | Exchanging input seal A2 |
| 9 | 0000-334-490 | SPP gear unit RV-500N i=252 (wo) | Gear A3 | |
| | 0000-334-495 | SPP input shaft RV-500N | | |
| | 0000-334-496 | SPP input seal RV-500N | | Exchanging input seal A3 |
| 10 | 0000-311-666 | CBS assy, type GA20 | Counterbalancing system | 更换平衡配重 |
| 11 | 0000-325-606 | Cable set INT 084ST2700 | Cable set | Exchanging the cable set |
| 12 | 0000-254-559 | Resolver Digital Converter RDC cool | RDC | |
| 13 | 0000-236-267 | Electronic Data Storage EDS Cool | EDS | |
| 14 | 0000-106-814 | Gauge cartridge IP67 (A20) short | Gauge cartridge | |

Export to Excel 

Maintenance information

Gear oil



The quantity of oil drained depends on the draining time and the oil temperature. The refilling quantity is the quantity of oil that was drained from the gear unit at the correct operating temperature and with the correct draining time. This oil quantity must be determined. Only this quantity of oil may be used when refilling.

If less than 70 % of the specified oil quantity flows out, flush the gear unit with the determined quantity of drained oil once, then pour in the amount of oil that was drained. If less than 50% of the specified oil quantity flows out (e.g. inclined installation), the flushing operation must be repeated twice. During the flushing procedure, move the axis at jog velocity throughout the entire axis range.

The oil quantities specified in the table correspond to the oil quantities in the gear unit at first filling.

| Gear oil new filling quantity | |
|-------------------------------|--------|
| A1 | 5.70 l |
| A2 | 2.10 l |
| A3 | 1.40 l |
| A4 | 2.10 l |
| A5 / A6 | 1.90 l |
| Gear oil refilling quantity | |
| A1 | - |
| A2 | - |
| A3 | - |
| A4 | - |
| A5 / A6 | - |

Counterbalancing system

| | |
|------------------------|---------|
| Gas pressure p0 | 156 bar |
| Oil pressure p1 | 176 bar |

Technical data

Basic data

| | KR 250 R2700-2 |
|--|---|
| Number of axes | 6 |
| Number of controlled axes | 6 |
| Volume of working envelope | 56.3 m ³ |
| Pose repeatability (ISO 9283) | ± 0.05 mm |
| Weight | approx. 1101 kg |
| Rated payload | 250 kg |
| Maximum payload | 315 kg |
| Maximum reach | 2701 mm |
| Protection rating (IEC 60529) | IP65 |
| Protection rating, in-line wrist (IEC 60529) | IP65 / IP67 |
| Sound level | < 75 dB (A) |
| Mounting position | Floor |
| Footprint | 754 mm x 754 mm |
| Hole pattern: mounting surface for kinematic system | S780 |
| Permissible angle of inclination | ≤ 5 ° |
| Default color | Base frame: black (RAL 9005); Moving parts: KUKA orange 2567 |
| Controller | KR C4 |
| Transformation name | KR C4: KR250R2700_2 C4 FLR |

Ambient conditions

| | |
|--|----------------------------------|
| Humidity class (EN 60204) | - |
| Classification of environmental conditions (EN 60721-3-3) | - |
| Ambient temperature | |
| During operation | 0 °C to 55 °C (273 K to 328 K) |
| During storage/transportation | -40 °C to 60 °C (233 K to 333 K) |

Axis data

| | |
|---------------------------------|----------------|
| Motion range | |
| A1 | ±185 ° |
| A2 | -140 ° / -5 ° |
| A3 | -120 ° / 168 ° |
| A4 | ±350 ° |
| A5 | ±122.5 ° |
| A6 | ±350 ° |
| Speed with rated payload | |
| A1 | 105 °/s |
| A2 | 107 °/s |
| A3 | 107 °/s |
| A4 | 170 °/s |
| A5 | 129 °/s |
| A6 | 206 °/s |

Working envelope

Dimensions: mm

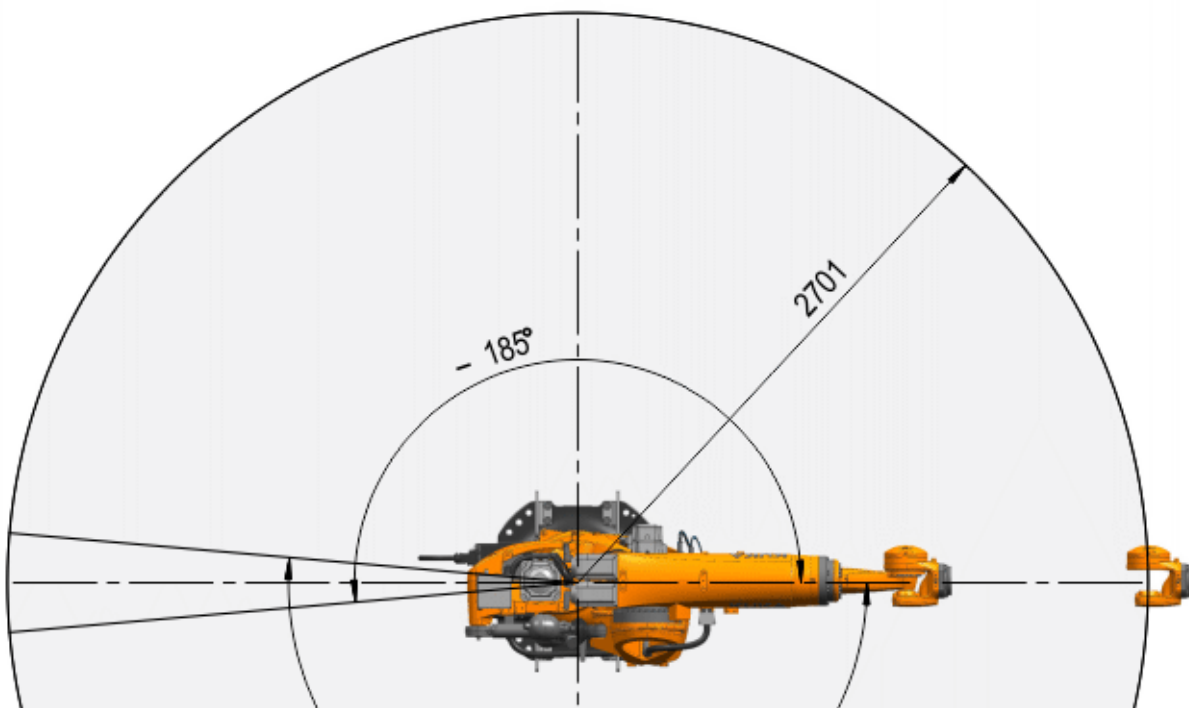
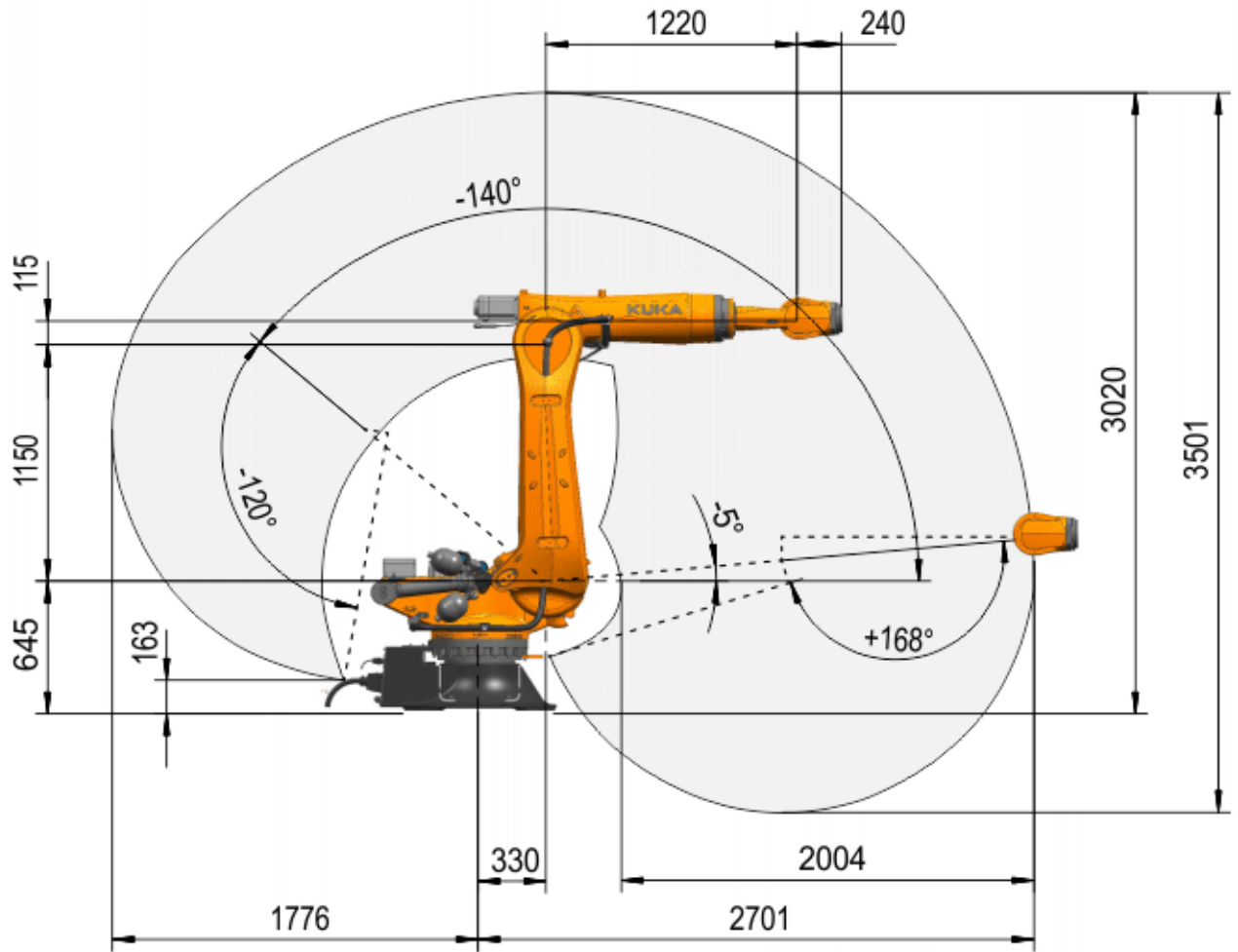

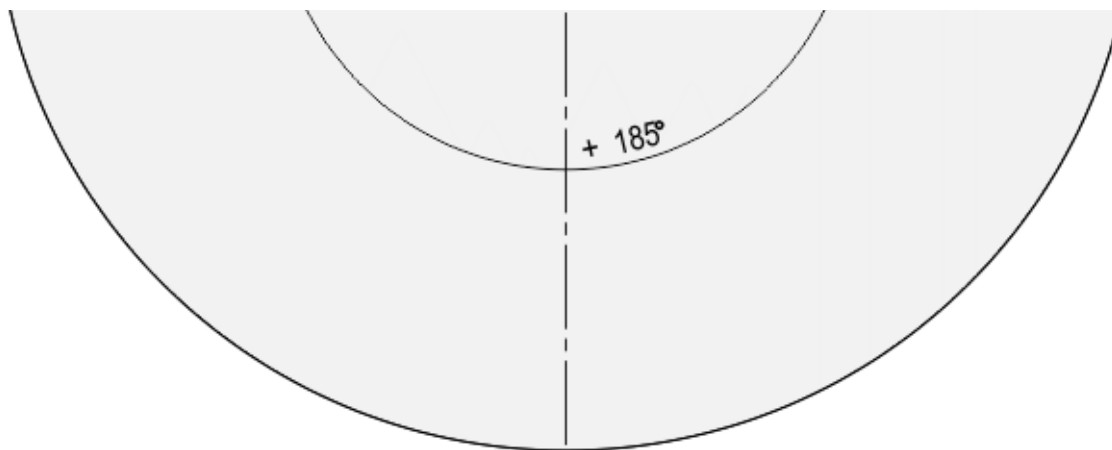

KR 250 R2700-2 , working envelope, overall

Payloads

| | |
|---|--------|
| Rated payload | 250 kg |
| Maximum payload | 315 kg |
| Rated supplementary load, base frame | 0 kg |
| Maximum supplementary load, base frame | 0 kg |
| Rated supplementary load, rotating column | 0 kg |
| Maximum supplementary load, rotating column | 300 kg |
| Rated supplementary load, link arm | 0 kg |
| Maximum supplementary load, link arm | 130 kg |
| Rated supplementary load, arm | 50 kg |
| Maximum supplementary load, arm | 150 kg |

Dimensions: mm

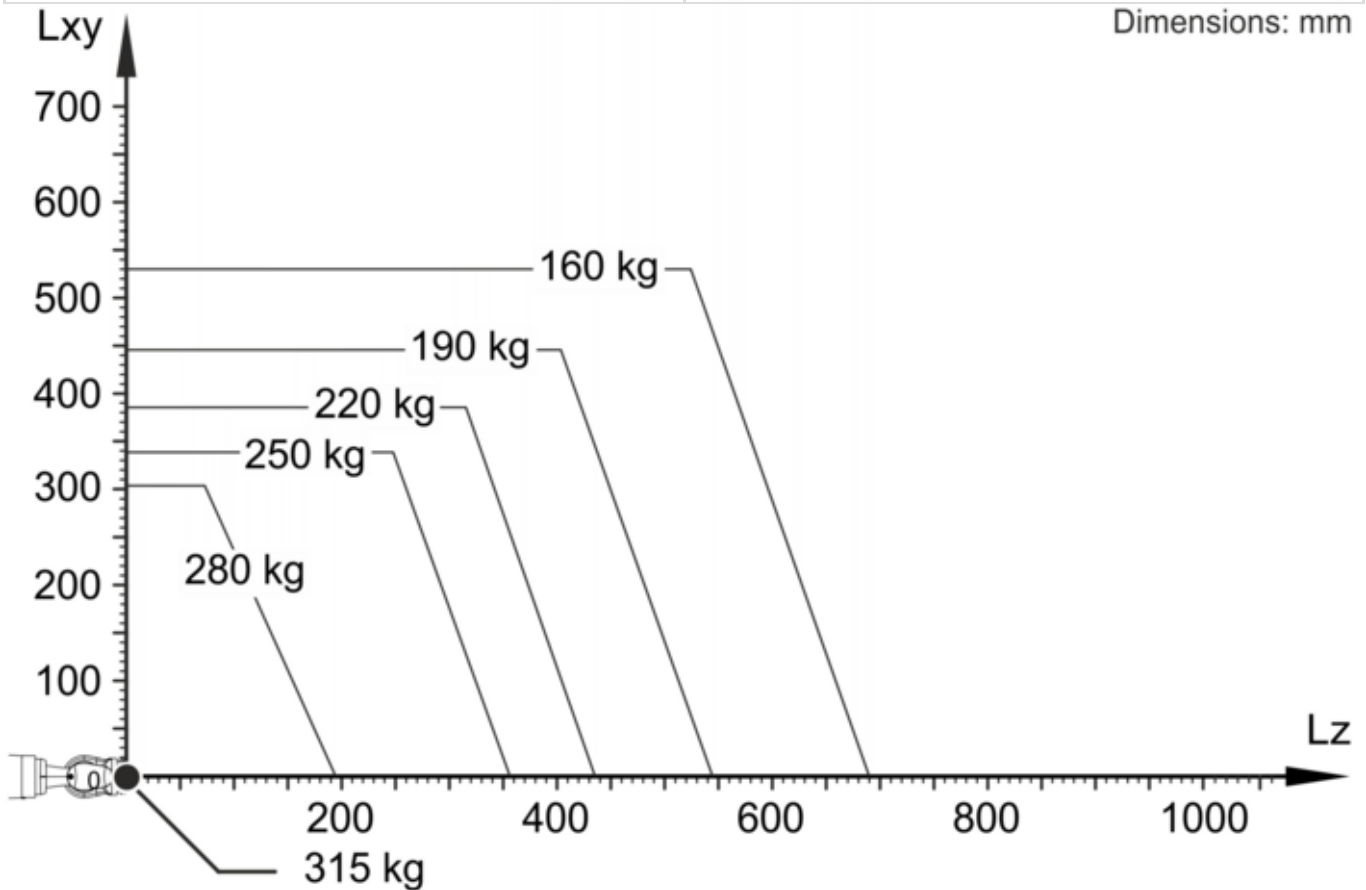

KR 250 R2700-2 , payload diagram

Mounting flange

| | |
|--------------------|-------------|
| In-line wrist type | ZH300 |
| Mounting flange | see drawing |

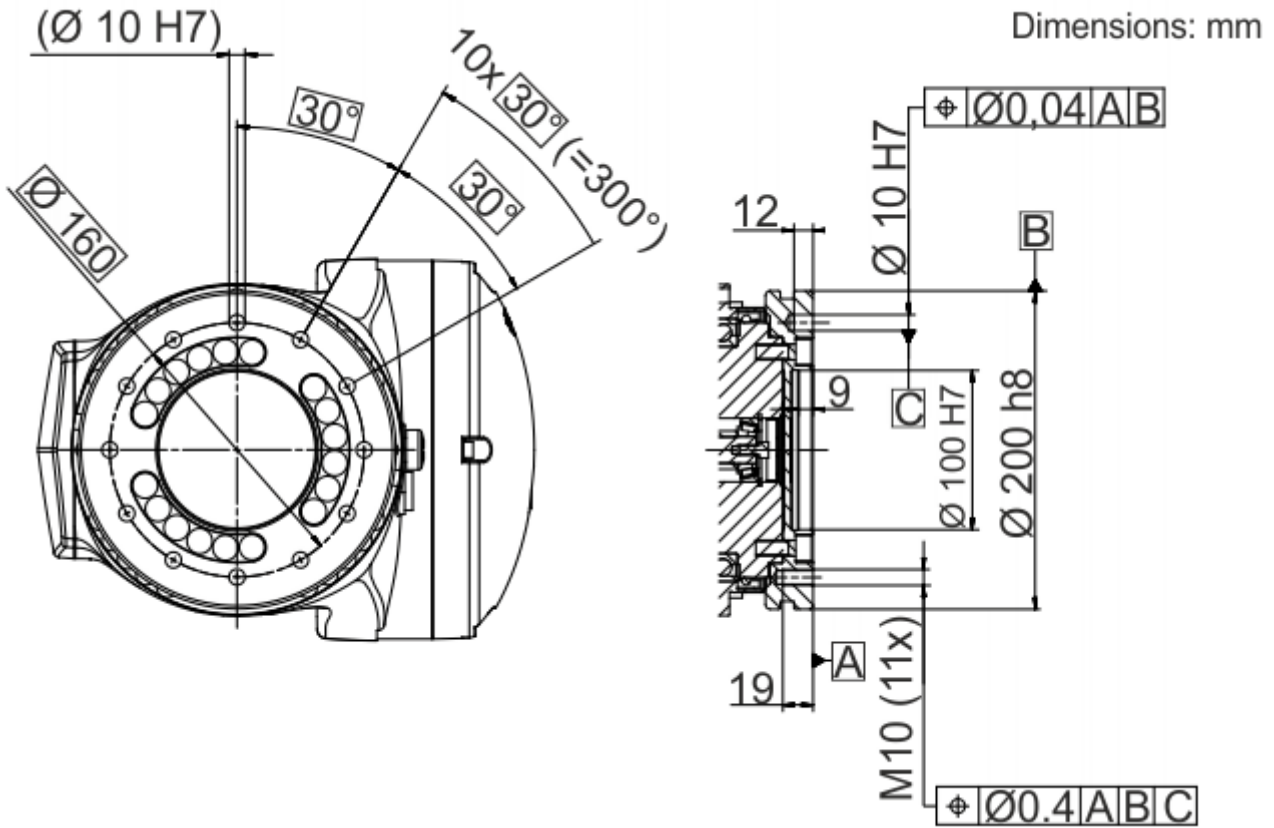

Mounting flange D=160

Foundation loads

| | |
|---------------------------------|----------|
| Vertical force F(v) | |
| F(v normal) | 18164 N |
| F(v max) | 24033 N |
| Horizontal force F(h) | |
| F(h normal) | 7626 N |
| F(h max) | 20063 N |
| Tilting moment M(k) | |
| M(k normal) | 22790 Nm |
| M(k max) | 38237 Nm |
| Torque about axis 1 M(r) | |
| M(r normal) | 7817 Nm |
| M(r max) | 17833 Nm |

Vertical force F(v), horizontal force F(h), tilting torque M(k), torque about axis 1 M(r)

Process forces

Process forces are forces that are exerted on the robot in a defined manner by an external influence. Causes include pressing processes and machining tasks carried out by the robot. The process forces that the robot can withstand depend to a very great degree on the robot position, payload, direction and duration of action. For this reason, it is not possible for a simple limit value to be specified for permissible process forces.

Permissible process torques are therefore specified for all axes of the robot. These values indicate the torque that each robot axis can withstand on a sustained basis as a result of external forces.

The following load torques must not be exceeded:

| | |
|-----------|---------|
| A1 | 5000 Nm |
| A2 | 5700 Nm |
| A3 | 5700 Nm |
| A4 | 1650 Nm |
| A5 | 1650 Nm |
| A6 | 1000 Nm |

Flange loads

Flange loads

Due to the motion of the payload (e.g. tool) mounted on the robot, forces and torques act on the mounting flange. These forces and torques depend on the motion profile as well as the mass, load center of gravity and mass moment of inertia of the payload.

The specified values refer to nominal payloads at the nominal distance and do not include safety factors. It is imperative for the load data to be entered in the robot controller. The robot controller takes the payload into consideration during path planning. A reduced payload does not necessarily result in lower forces and torques.

The values are guide values determined by means of trial and simulation and refer to the most heavily loaded machine in the robot family. The actual forces and torques may differ due to internal and external influences on the mounting flange or a different point of application. It is therefore advisable to determine the exact forces and torques where necessary on site under the real conditions of the actual robot application.

The operating values may occur permanently in the normal motion profile. It is advisable to rate the tool for its fatigue strength.

The EMERGENCY STOP values may arise in the event of an Emergency Stop situation of the robot. As these should only occur very rarely during the service life of the robot, a static strength verification is usually sufficient.

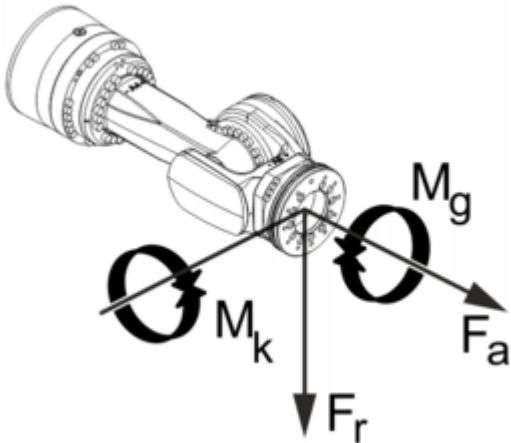

Flange loads

| Flange loads during operation | |
|-------------------------------|---------|
| F(a) | 5127 N |
| F(r) | 4555 N |
| M(k) | 3410 Nm |

| | |
|---|---------|
| M(g) | 1649 Nm |
| Flange loads in the case of EMERGENCY STOP | |
| F(a) | 8571 N |
| F(r) | 11250 N |
| M(k) | 6393 Nm |
| M(g) | 5225 Nm |

Axial force $F(a)$, radial force $F(r)$, tilting torque $M(k)$, torque about mounting flange $M(g)$

轨迹精度

线性运动的轨迹精度:

| | |
|-------------------------------|----------------------|
| LIN 轨迹绝对精度 (ISO 9283) | $\pm 1.1 \text{ mm}$ |
| SLIN 轨迹绝对精度 (ISO 9283) | $\pm 0.9 \text{ mm}$ |
| 轨迹重复精度 线性 (ISO 9283) | $\pm 0.2 \text{ mm}$ |

该数据针对的是 1 m/s 的参考速度。

圆周运动的轨迹精度:

| | |
|--------------------------------|----------------------|
| CIRC 轨迹绝对精度 (ISO 9283) | $\pm 1 \text{ mm}$ |
| SCIRC 轨迹绝对精度 (ISO 9283) | $\pm 0.8 \text{ mm}$ |
| 圆周轨道重复精度 (ISO 9283) | $\pm 0.2 \text{ mm}$ |

该数据针对的是 0.5 m/s 的参考速度。

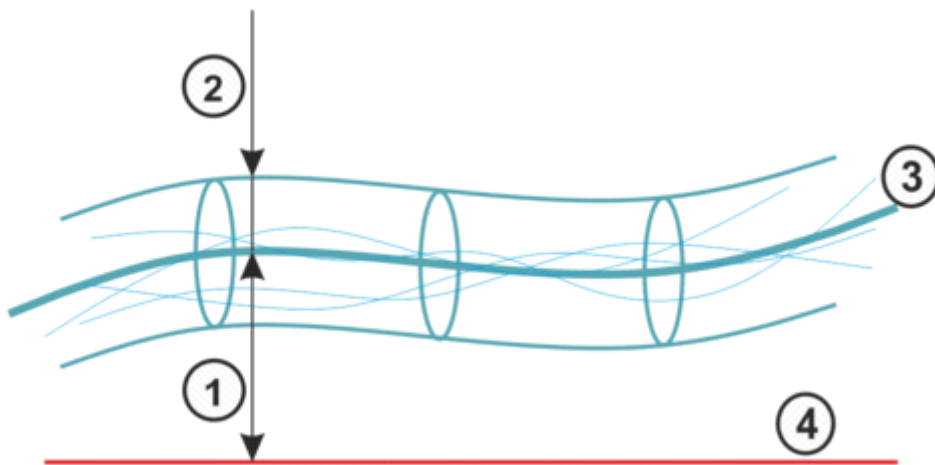

轨迹精度

| | | | |
|---|--------|---|----------|
| 1 | 轨迹绝对精度 | 3 | 运行轨迹的平均值 |
| 2 | 轨迹重复精度 | 4 | 编程的轨迹 |

- 轨迹精度表示机器人在编程的轨迹上运动的能力。
- 轨迹重复精度表示 10 个运行轨迹与运行轨迹平均值的偏差。

超调状态

| | |
|------|--------|
| 振幅 | 0.5 mm |
| 定位时间 | 0.6 s |

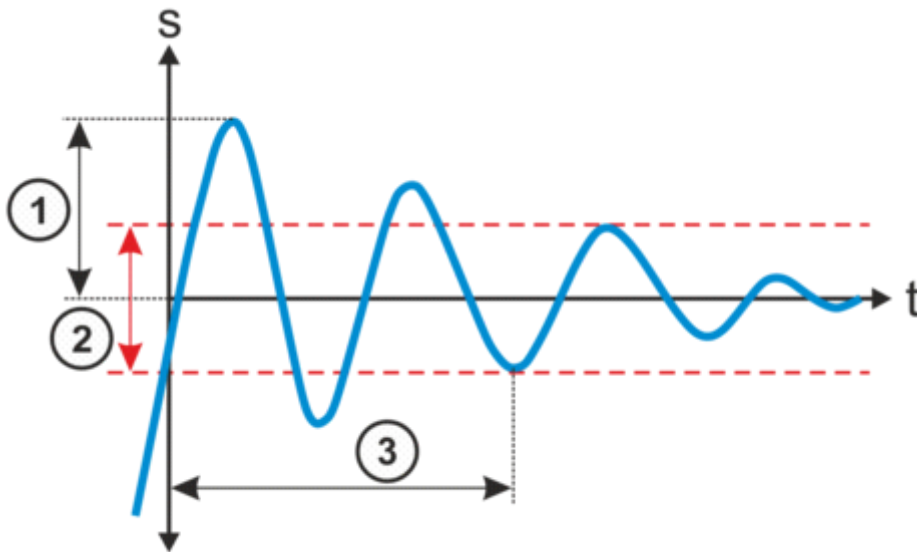

超调状态

| | | | |
|---|------|---|------|
| 1 | 超调振幅 | 3 | 定位时间 |
| 2 | 公差范围 | | |

- 超调振幅影响机器人在特定位置执行受控的精确暂停的能力。
- 定位时间表示机器人在特定位置上停止的速度。

更多的信息

- 给出的数据基于 ISO 9283，并使用 Krypton/Metris 的基于摄像机的系统测得。因此重复精度被定义为 3 sigma 值。
- 所有数值均以额定负载测得。

关税信息

| | |
|------|----------|
| 统计货号 | 84795000 |
| 原产地 | DE |
| 制造商 | - |
| 重量 | 1101 kg |

- > **KR 250 R2700-2** 需要 (8)
- > **KR 250 R2700-2** 带有如下的工具 (26)
- > **KR 250 R2700-2** 带有如下的备件 (17)
- > **KR 250 R2700-2** 有以下选项 (59)